

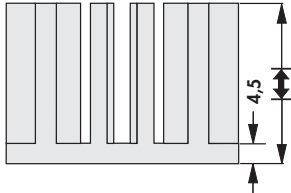

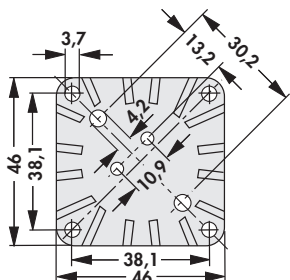



	
art. no.	\pm [mm]	R_{th} [K/W]	\emptyset
FK 318 SA 3	31.8	4.8	TO 3
material:	die-casting aluminium		
surface:	black lacquered		

– packing unit = 24 pieces

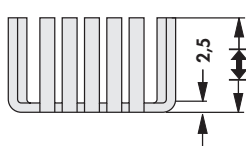
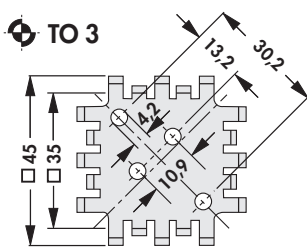
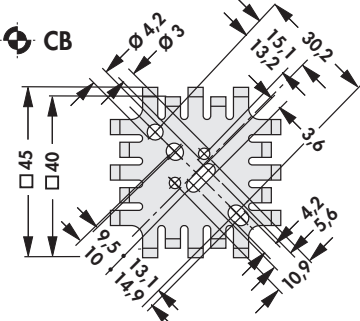
			
art. no.	\pm [mm]	R_{th} [K/W]	\emptyset
FK 254 1 SA	25.4	5.4	without
FK 254 1 SA 3			TO 3
FK 318 1 SA	31.8	4.4	without
FK 318 1 SA 3			TO 3
material:	aluminium, Al99.5, cold extruded part		
surface:	black anodised		

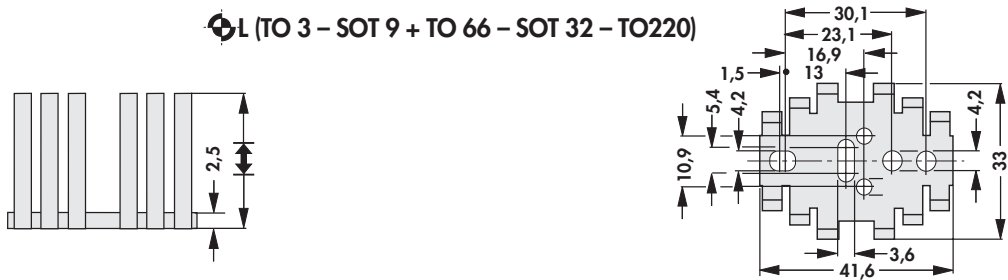
			
art. no.	\pm [mm]	R_{th} [K/W]	\emptyset
FK 201 SA	25.4	6	without
FK 201 SA 3			TO 3
FK 201 SA CB			CB
FK 202 SA	12.7	8	without
FK 202 SA 3			TO 3
FK 202 SA CB			CB
material:	aluminium		
surface:	black anodised		

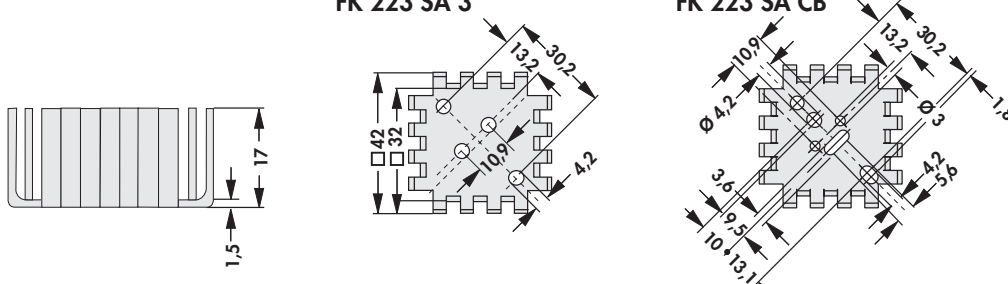
	<p style="text-align: center;">⌀L (TO 3 – SOT 9 + TO 66 – SOT 32 – TO220)</p> 		
art. no.	\pm [mm]	R_{th} [K/W]	⌀
FK 205 SA L	31.8	9.0	L
FK 206 SA L	25.4	10.5	
FK 207 SA L	19.1	12.0	
FK 208 SA L	12.7	14.0	
	<p style="text-align: center;">FK 223 SA 3 FK 223 SA CB</p> 		
art. no.	R_{th} [K/W]	⌀	
FK 223 SA	6.8	without	
FK 223 SA 3		TO 3	
FK 223 SA CB		CB	
			
art. no.	R_{th} [K/W]	⌀	
FK 217 SA CB 2	16	CB 2 (SOT 32; TO 220)	
material:	aluminium		
surface:	black anodised		